

Fast Switching PIN Diodes

Application Note 929

Switching Speed Definitions

The switching speed of a PIN diode may be defined and measured in a number of ways. Ideally, we would like to think of it as the time it takes the device to make the transition from the minimum insertion loss case to the maximum isolation case or vice versa. Because of the charge nonlinearities during switching of the device and the need for reasonable measurement techniques, we often settle for some definitions less than ideal.

A figure of switching capability commonly used by industry is the reverse recovery time (t_{rr}). Figure 1a shows the diode in the RF test circuit. Figure 1b shows the monitored current through the diode used to determine the reverse recovery time.

Note that under initial conditions, a forward bias (I_F) is forcing a charge equilibrium to exist in the intrinsic layer of the PIN diode. This equilibrium charge can be represented by $I_F\tau$ where τ is the minority carrier lifetime. To totally remove this charge, it is necessary to apply a reverse current through the device such that $I_F\tau = \int_{t_0}^{\infty} i_1 dt$. In other words, the total area under the reverse

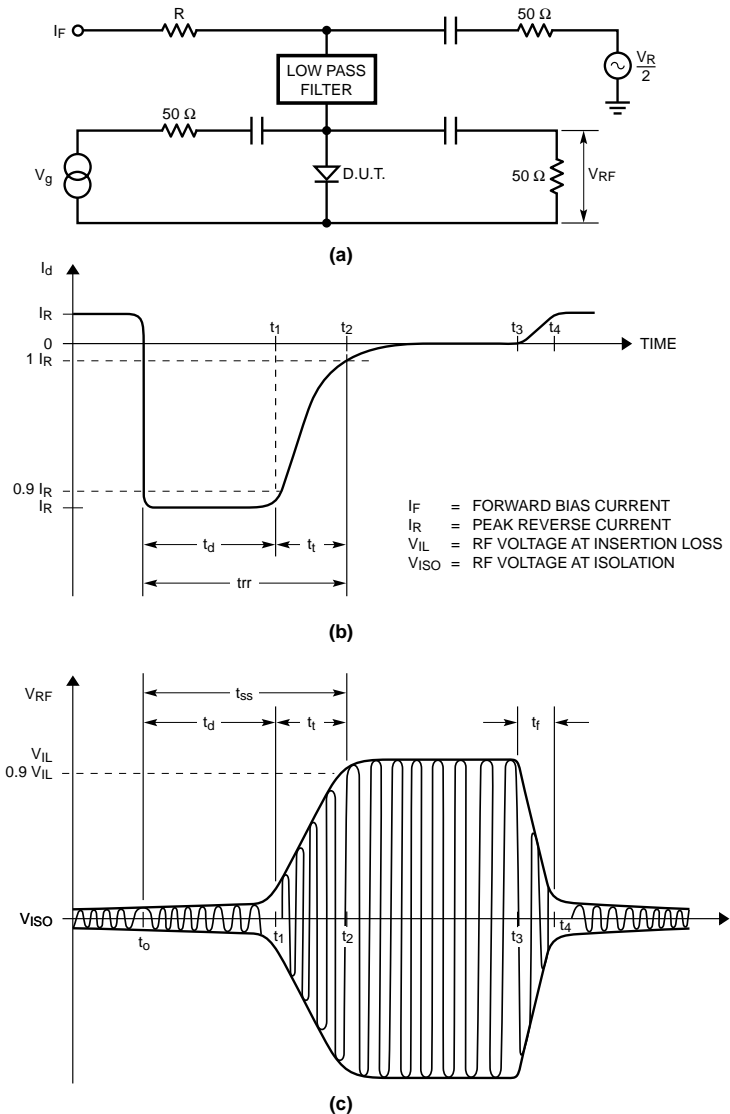

Figure 1. Switching Time Test Circuit with Drive Current Waveform and Switched RF Voltage

current vs. time curve just equals the charge stored under the forward bias conditions. This relation holds as long as $(t_2 - t_0) \ll \tau$, otherwise charge will be dissipated through recombination. It can be seen from Figure 1b that two prominent states may exist during reverse recovery. The first state from t_0 to t_1 is essentially a plateau of constant reverse current and impedance. This is called the delay time and it may be varied easily by changes in the ratio of forward current I_F and peak reverse current I_R , i.e.,

$$t_d \propto \frac{I_F}{I_R}.$$

The second region is that known as the transition time and denotes the interval during which the impedance of the diode is changing very rapidly. This transition time depends primarily on diode design, i.e., doping profile and geometry, and only slightly on the forward bias current. It should be emphasized that **the minimum realizable time it takes to switch between the two impedance states is the transition time part of the reverse recovery waveform.** Figure 2 illustrates that devices manufactured by different processes may have

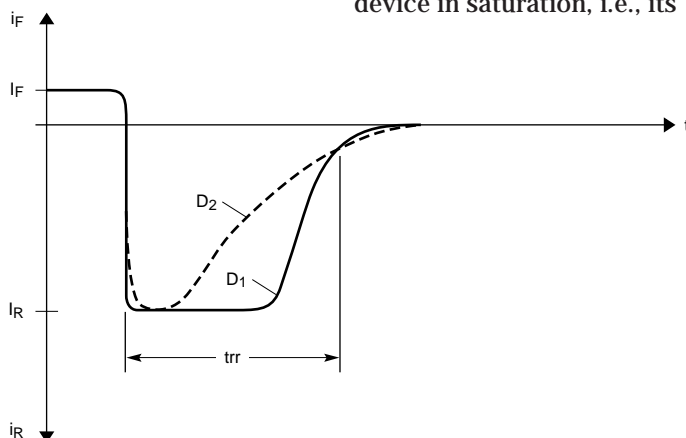

Figure 2. Reverse Recovery Time for Differently Processed Diodes

identical reverse recovery times under similar drive conditions, but considerably different transition times. It may be seen that D_2 cannot be switched much faster than t_{rr} . To switch D_1 means reducing the delay time, a simple matter of decreasing forward current or increasing peak reverse current. The HP fast switching PIN diodes are designed to yield as short a transition time as possible, yet keep their identity as a PIN. Retaining PIN identity is a significant benefit to the customer requiring a switching or modulating device capable of low harmonic distortion.

The reverse recovery time is the sum of the delay time and the transition time, and is measured from the zero current crossing of the reverse current to the time at which the reverse current is 90% down from its maximum value.

The reverse recovery time has a close analogy to how fast the device will react to a drive pulse and switch an RF signal. Consider the compensated shunt PIN 5082-3141; during the delay time a constant reverse current is flowing and the RF impedance changes only slightly. This impedance would be that set up by the previously flowing forward bias, I_F . If the forward bias put the device in saturation, i.e., its

lowest impedance state, then the delay time would indicate the time during which the switch remained in its maximum isolation state. During the transition period, the diode's impedance is changing from its lowest value to some relatively high value. At the end of t_t , the switch will be in a relatively low attenuation state, i.e., insertion loss condition. Figure 1c shows the switched RF voltage when the diode is driven by the same forward and reverse current characteristic as Figure 1b. Here we will define the switching speed as to which is the time from pulse initiation (t_0) to 90% of the RF voltage appearing across the load when the switch is in the insertion loss state. If we look at t_{ss} it appears approximately equal to t_{rr} ; however, as defined, the time t_{ss} does not necessarily equal the reverse recovery time (t_{rr}) but rather depends on the device reaching a specific RF impedance. The total insertion loss of the device at time t_{ss} will be its steady state insertion loss at the frequency of interest plus 0.9 dB.

It should now be obvious that t_{rr} is in itself not descriptive of the minimum time an RF signal may be switched from maximum isolation to insertion loss or vice versa. The following section on drive requirements will consider the device under actual use conditions. The HP 5082-3141 will be used as an example for the following discussions. These devices are the fast switching PIN in the compensated stripline packages. For this reason, no matching structure is necessary to obtain maximum isolation or minimum insertion loss, and the switch configuration is that of a shunt-mounted diode.

Basic Drive Requirements

The HP Stripline series is designed to switch over very high

isolation to insertion loss ratios with an absolute minimum of required drive power. The following are considerations to be taken before settling on the drive network.

Isolation Required

To obtain the maximum isolation, the forward bias current should completely saturate the intrinsic region with charge producing the lowest possible impedance level. The region approaching saturation is extremely nonlinear in that large increases in forward current produce very small decreases in the residual impedance (see Figure 3) while still injecting considerable charge. To remove this charge requires considerable reverse bias current or a long delay time. For minimum switching times, the device should be biased only to the extent needed to obtain the required isolation. For example, at 2 GHz, an increase of forward bias from 10 mA to 20 mA produces an isolation increase of only 2 dB, yet means a switching time increase from 3 to 4 ns for a reverse pulse of 10 volts.

Switching Time Required

Figure 4 indicates typically what is required in forward bias and peak reverse voltage to initiate a particular switching speed, t_{SS} .

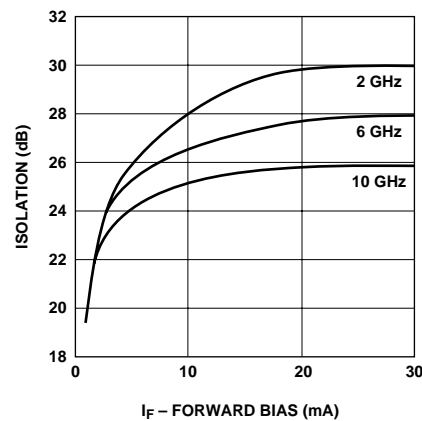

Figure 3. Typical Isolation vs. Forward Bias

The switching speeds illustrated are for a shunt diode switching from isolation to insertion loss, i.e., from storage to depletion of intrinsic layer charge. In the opposite case, switching to forward bias, the isolation follows the risetime of the driving pulse after an initial 2 nanosecond delay. It can be seen that driving of the diode from a forward biased state to reverse bias is the important consideration in determining the switching speed.

When driving the HP fast switching diode, the following parameters should be considered in the design of a driver to optimize the switching time:

- Reverse pulse voltage available
- Forward bias current available
- Driver impedance
- Pulse risetime
- Frequency of switched RF
- Allowable drive pulse leakage to the RF line

These parameters and their role in driver design will be discussed in the following section on switch configurations.

Switching Considerations

One of the most widely used and easiest switch configurations to drive is that utilizing the diode in shunt with the RF line. We will

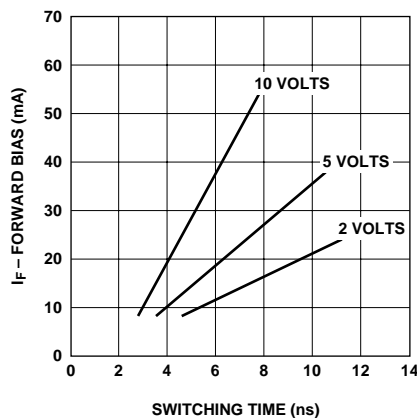

Figure 4. Switching Time vs. Forward Bias for Peak Reverse Voltage as a Parameter

consider here the basic considerations necessary to optimize the use of the HP fast switching stripline packaged PIN. This fast switching PIN is also available in other package styles with basically similar drive requirements.

Driving the Diode from Forward to Reverse Bias

As a shunt element in a 50-ohm RF system, the diode's impedance state appears as the effective load to the drive source. If the diode is initially forward biased and a reverse bias pulse is used to turn it off, then the peak reverse current flowing through the diode will simply be the open circuit pulse voltage divided by the drive impedance. By consulting Figure 3, the desired isolation may be transposed to the necessary forward bias current. From Figure 4, the forward bias current may be used to determine either the switching time when the peak reverse voltage is known or the peak reverse voltage necessary when a desired switching time is required. With the reverse voltage decided upon, the proper combination of driver impedance, voltage, and risetime may be set to yield the desired speed. For optimized switching, the reverse drive pulse risetime should be less than one-half the transition time, which for these devices is approximately 2 nanoseconds. Very short drive pulse risetimes should not be used if minimum filtering and low pulse leakage to the RF line is desired. Higher than necessary reverse pulse magnitudes will also increase the drive pulse leakage and result in the need for additional filtering.

Driving the Diode from Reverse to Forward Bias

When driving the diode into forward conduction, the desired isolation will set the forward bias current, and the risetime of the

switch will simply follow that of the driver after a 2 nanosecond delay. Here again, the allowable pulse leakage and degree of filtering will set a limit on the minimum risetime.

Practical Switching Circuits

Figures 5a, b, and c illustrate just a few of the realizable switching networks using a shunt-mounted PIN. Figures 5a and b are possibly the most commonly used and are relatively easy to produce in any transmission line system. The low

pass filter cutoff frequency is determined by the minimum drive pulse risetime and should offer high isolation of the RF line from the driver. For a one-nanosecond drive pulse risetime, this cutoff frequency is approximately 400 MHz. The RF line filters may be either high pass for broadband switching or band pass for narrowband. In Figure 5b, the feedthrough capacitor, C_1 , acts as a pulse source low pass and the RF ground.

The design of high pass filters will

depend upon the degree of drive pulse leakage allowable. If the difference in frequency between the low pass cutoff and the RF signal is large, then often only capacitive coupling is necessary to reduce the leakage to acceptable levels. A problem with the basic design in Figure 5a is that for broadband operation, high isolation of the RF signal from the drive line is difficult to obtain and often compromises produce ringing of the pulsed RF. A cleaner method of entering the RF line from the driver is shown in Figure 5c. Here, a tapered polyiron load is used as a low pass filter while acting as an excellent broadband termination for the RF signal. The polyiron load will have a minimum effect on the pulse risetime if its length is set for a minimum signal frequency of operation approximately two octaves higher than the required drive pulse bandwidth. For example, at a signal frequency of 2 GHz, three inches $\frac{1}{2}\lambda$ will offer a good signal termination with less than 20 percent degradation of a one-nanosecond drive pulse. At much higher frequencies, the physical load length required reduces in proportion to the decrease in wavelength, with practically no degradation to the drive pulse risetime.

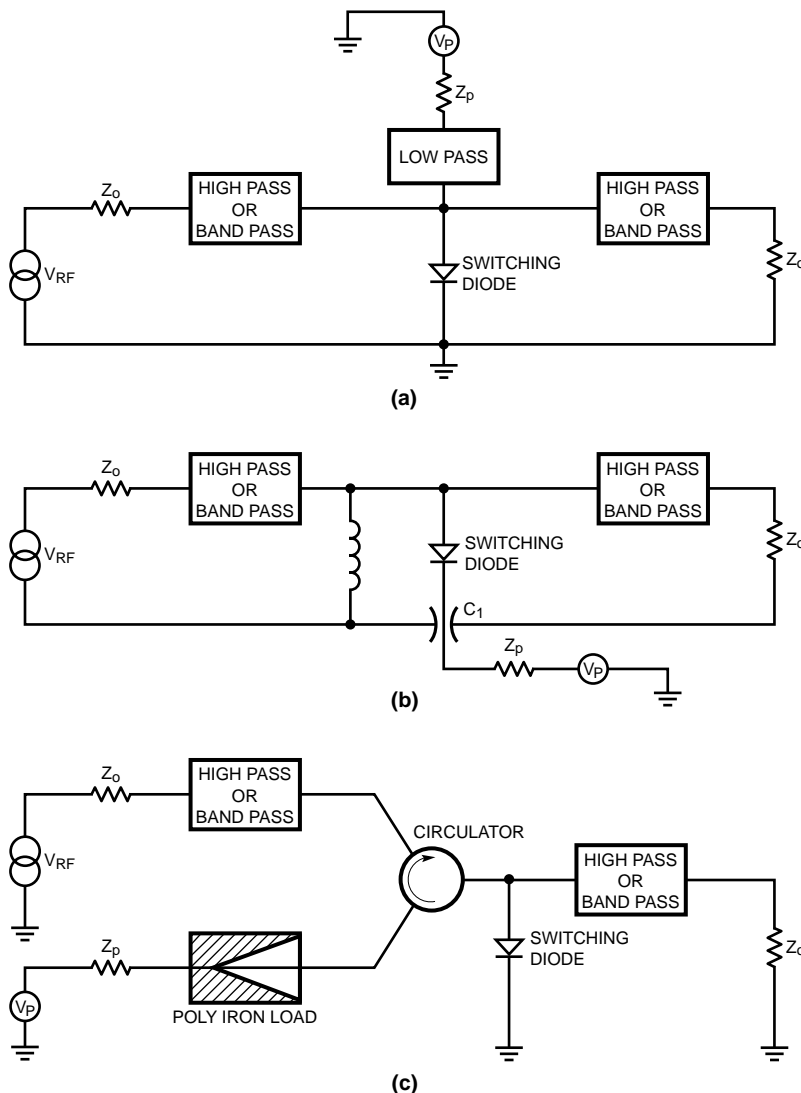

Figure 5

For technical assistance or the location of your nearest Hewlett-Packard sales office, distributor or representative call:
Americas/Canada: 1-800-235-0312 or (408) 654-8675
Far East/Australasia: Call your local HP sales office.
Japan: (81 3) 3335-8152
Europe: Call your local HP sales office.
 Data Subject to Change
 Copyright © 1997 Hewlett-Packard Co.
 Obsoletes 5091-9053E
 Printed in U.S.A. 5965-8668E (7/97)